

FIRST DEGREE FITNESS
Fluid INNOVATION

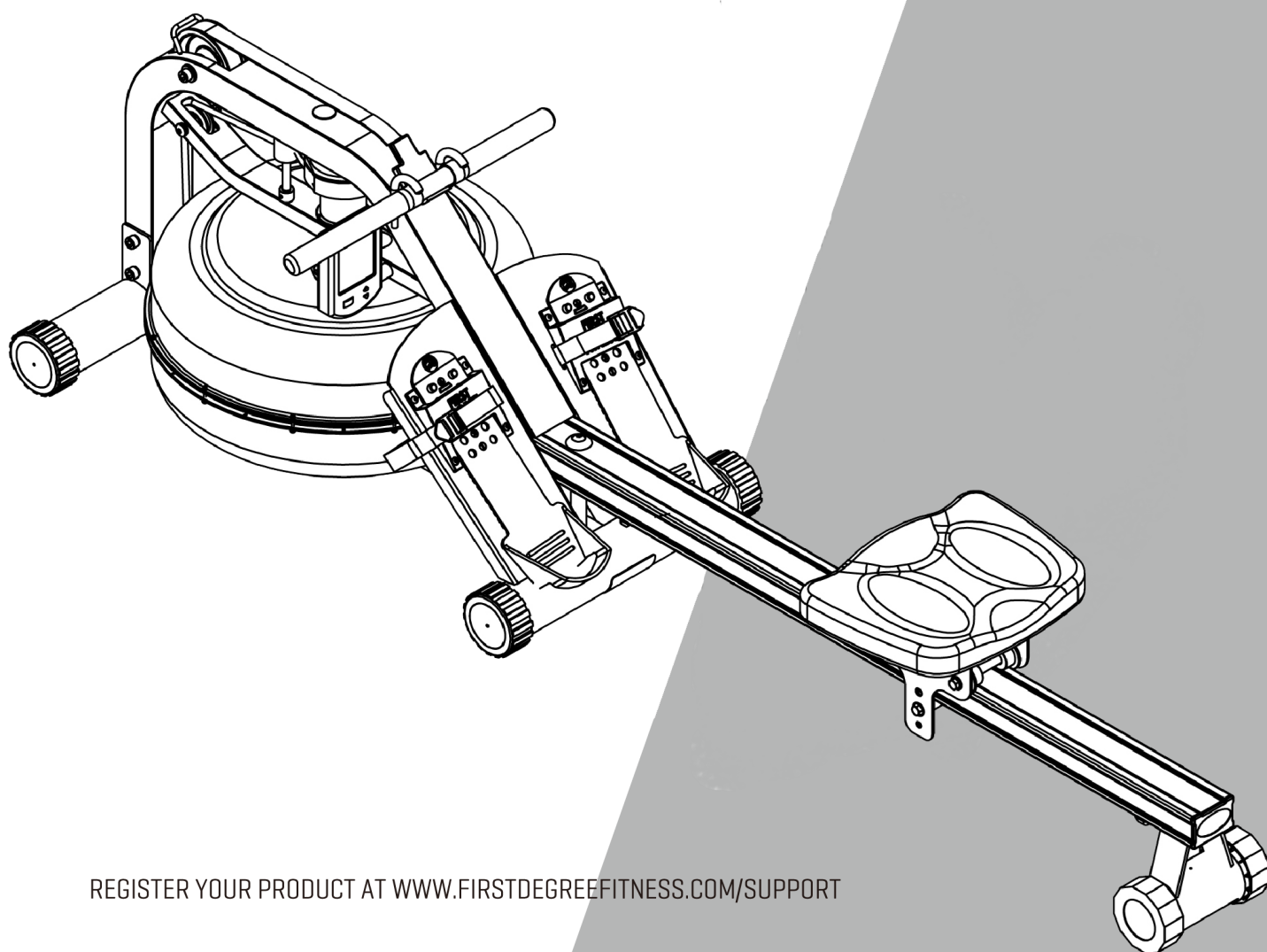

» USER GUIDE

PACIFIC AR
NEWPORT AR
DAYTONA AR



REGISTER YOUR PRODUCT AT WWW.FIRSTDEGREEFITNESS.COM/SUPPORT

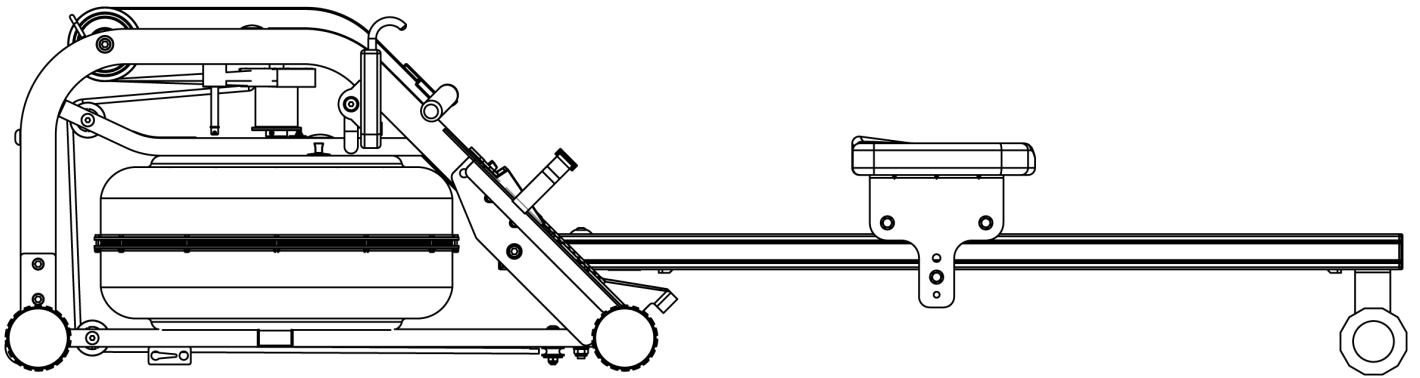

Congratulations on your purchase of Rower.

FIRST DEGREE FITNESS is proud to present the Rower as a home use product featuring patented Adjustable Fluid Resistance.

Follow all instructions carefully for correct assembly, tank filling, water treatment, service and safety.

Access to our world-wide distributor and service network is available at www.firstdegreefitness.com

Check contents of Box 1 and Box 2 to assure all parts are present and correct prior to assembly.

Training with the Rower

1. As with any piece of fitness equipment, consult a physician before beginning your Rower exercise program.
2. Follow instructions provided in this manual for correct foot position and basic rowing techniques.
3. For more detailed rowing techniques, please refer to our international website at www.firstdegreefitness.com

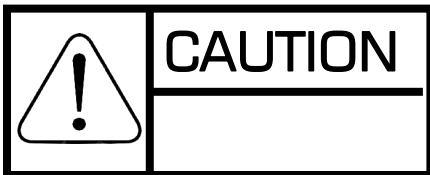

1. Keep hands and fingers away from moving parts, as indicated in this manual.
2. The Rower can stand vertically for storage. Make sure a secure location is chosen, such as the corner of a room or against a wall on an even, secure surface.

Note: If the storage area is not level, an additional fixture is required (sold separately) to keep the Rower stable with vertical storage position.

» Contents

Safety.....	5
Assembly.....	7
Fluid Rower Box Contents.....	8
Assembly Instructions.....	9
Fine Tuning the Fluid Rower.....	12
Adjustable Resistance (AR) Tank.....	13
Note on Filling the AR Tank.....	14
Tank Filling and Water Treatment.....	15
Removing/Changing Tank Water.....	16
Slider Footplate.....	17
How to Row?.....	18
How Often?.....	18
Computer Operation.....	19
Using the FIRST DEGREE FITNESS USB Interface.....	20
Detaching the Fluid Rower Belt.....	21
Reattaching the Fluid Rower Belt.....	22
Removing the Bungee Shock Cord.....	23
Replacing the Bungee Shock Cord.....	23
Maintenance.....	24
Troubleshooting.....	25
Optional Fixture Kit Installation	26
Product Exploded Diagram.....	27
Warranty.....	30

» Safety

Safety Information

- Before using this product, it is essential to read this ENTIRE operation manual and ALL instructions. The Rower is intended for use solely in the manner described in this manual.
- UNDERSTANDING EACH AND EVERY WARNING TO THE FULLEST IS IMPORTANT
- As with any piece of fitness equipment, consult a physician before beginning your Rower exercise program.
- Please be aware that any fitness regiment, before being undertaken, is best preceded by a physical checkup from a certified physician.
- Injuries to health may result from incorrect or excessive training.
-  **WARNING** Heart rate monitoring systems may be inaccurate. Over exercise may result in serious injury or death. If you feel faint, stop exercising immediately.
- Stop the machine immediately if any signs of excessive wearing is present on the belts, pulleys and bungee cords. Do not use unit until said parts are repaired or replaced.
- Do not allow children unattended access to the machine.
- The Rower can stand vertically for storage. When doing so, please follow the instructions given in the manual.
- Please keep hands away from moving parts, as indicated by the warning label on the mainframe of your machine.
- If any of the adjustment devices are left projecting, they could interfere with the user's movement.
- Do not store in freezing conditions with water in the tank as it can expand and crack the components.

Installation

- Place on a stable, flat surface in a horizontal position during use for maximum stability.
- Check all belts, pulleys and bungee cords regularly for signs of wear, and replace if needed.
- Check regularly and follow all instructions for maintenance as specified in this manual.
- Replace immediately any defective parts and do not operate unit until all repairs are complete.

» Safety



Proper Usage

- Do not use any equipment in any way other than designed or intended by the manufacturer. It is imperative that FIRST DEGREE FITNESS equipment is used properly to avoid injury.
- Injuries may result if exercising improperly or excessively. It is recommended that all individuals consult a physician prior to commencing an exercise program. If at any time during exercise you feel faint, dizzy or experience pain, STOP EXERCISING and consult your physician.
- Keep body parts (hands, feet, hair, etc.), clothing and jewelry away from moving parts to avoid injury.
- Follow instructions provided in this manual for correct foot position and basic rowing techniques.
- For more detailed rowing techniques, please refer to our International website www.firstdegreefitness.com

Inspection

- DO NOT use or permit use of any equipment that is damaged and/or has worn or broken parts. For all FIRST DEGREE FITNESS equipment use only replacement parts supplied by FIRST DEGREE FITNESS.
- Cables and belts pose an extreme liability if used when frayed. Always replace any cable or belt at first sign of wear (consult FIRST DEGREE FITNESS if uncertain).
- EQUIPMENT MAINTENANCE - Preventative maintenance is the key to smooth operating equipment as well as to keep your liability to a minimum. Equipment needs to be inspected at regular intervals.
- Ensure that any person(s) making adjustments or performing maintenance or repair of any kind is qualified to do so.
- DO NOT ATTEMPT TO USE OR REPAIR ANY ACCESSORY APPROVED FOR USE WITH THE FIRST DEGREE FITNESS EQUIPMENT WHICH APPEARS TO BE DAMAGED OR WORN.
- Check all belts, pulleys and bungee cords regularly for signs of wear, and replace if needed.
- Check regularly and follow all instructions for maintenance as specified in this manual.
- Replace immediately any defective parts and do not operate unit until all repairs are complete.

Operating Warnings

- Keep children away from the equipment. Parents or others supervising children must provide close supervision of children if the equipment is used in the presence of children.
- Do not allow users to wear loose fitting clothing or jewelry while using equipment. It is also recommended to have users secure long hair back and up to avoid contact with moving parts.
- All bystanders must stay clear of all users, moving parts and attached accessories and components while machine is in operation.
-  **WARNING** Do not insert fingers into tank!
-  **CAUTION** Do not fill past the calibration mark as indicated on the tank level sticker or water spillage can occur.
-  **WARNING** Never operate this rower without feet properly secured in Footstraps, or without the sliding portion of the Slider Footplate locked into position!

» Assembly

Specifications

Fluid Rower is not suitable for therapeutic purposes.

Product Class	HC
Braking System	Speed Independent
Product Gross Weight	63.05lb (27.6kg)
Max User Weight	330lb(150kg)
Minimum Safe Operating Surface Area	125.59"(319cm)Length x 67.71"(172cm) Width
Dimensions	78.35" (199cm) Length x 20.47" (52cm) Width x 22.04" (56cm) Height

The live area shall be not less than 23.62" (60cm) greater than the training area in the directions from which the equipment is accessed. The live area must also include the area for emergency dismount.

Live area and Training area

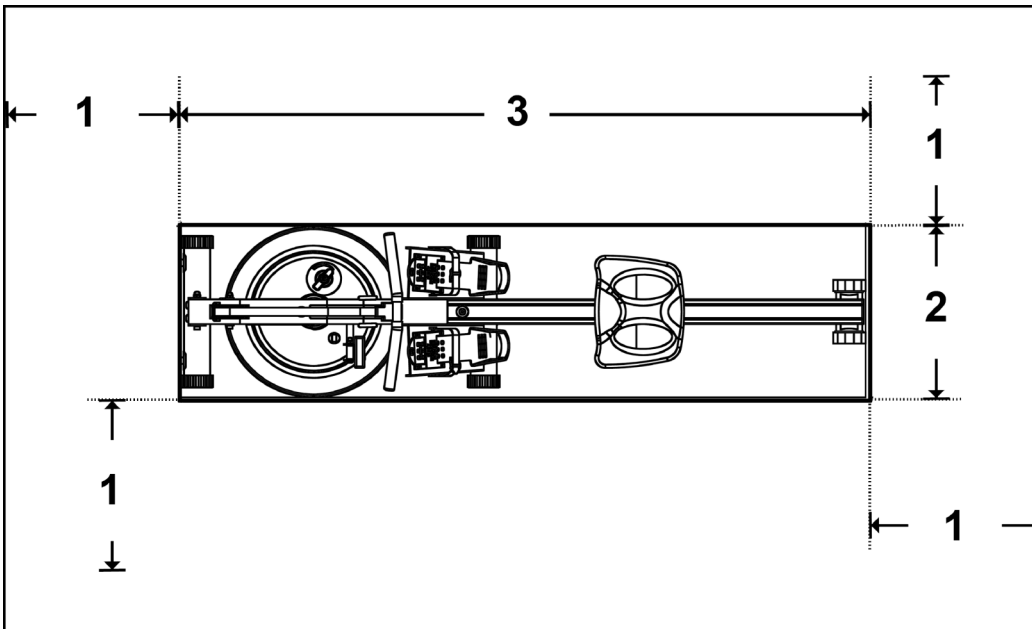

1	23.62" (60 cm) Live Area
2	20.47" (52 cm) Live Area
3	78.35" (199cm) Training Area

» Fluid Rower Box Contents

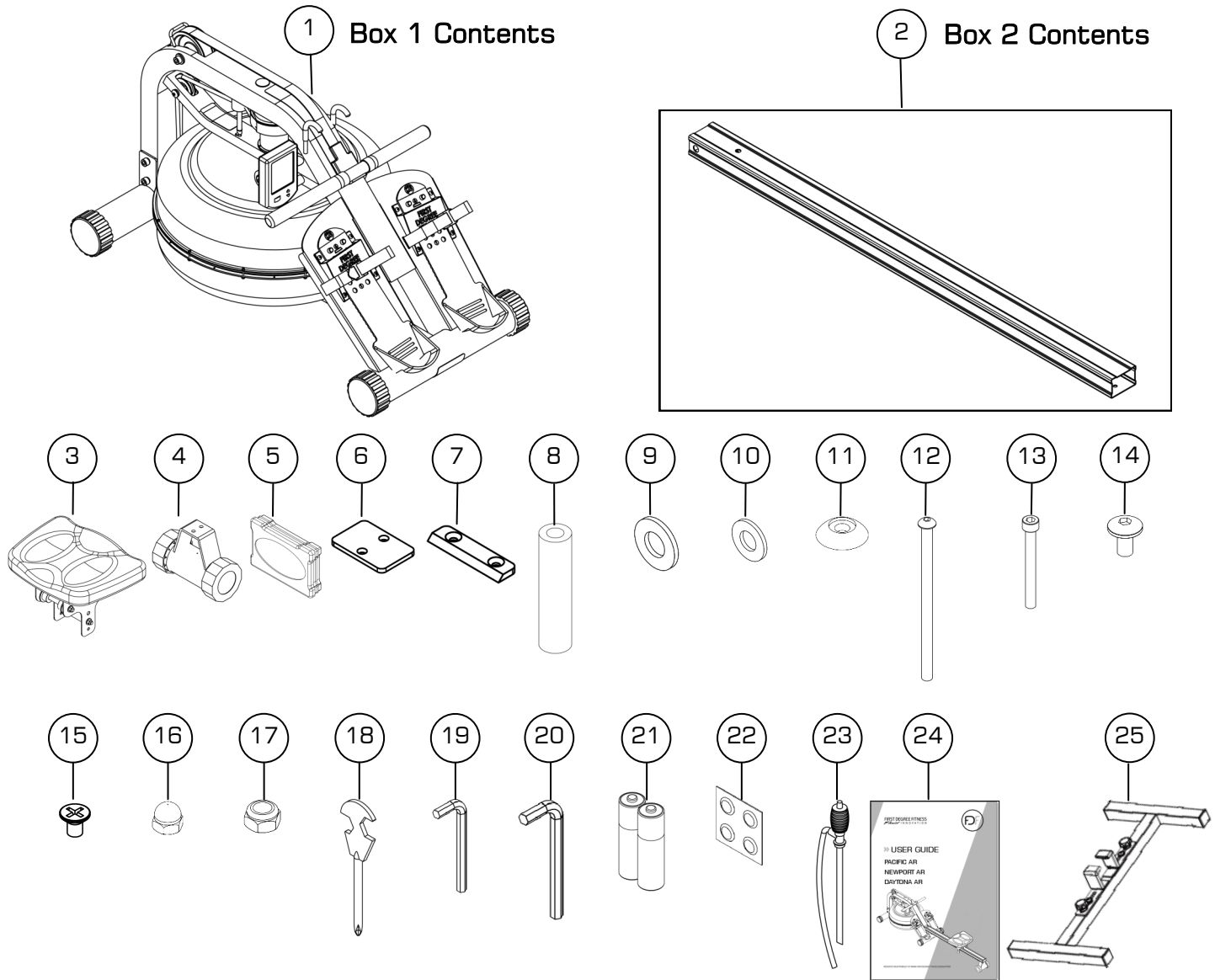

Item	Qty.	Description	Item	Qty.	Description
1	1	Main Frame	14	2	M8x15mm Rear Leg Bolts
2	1	Seat Rail (Boxed Separately)	15	2	M6x10 Countersink Bolts
3	1	Fluid Rower Seat	16	1	M10 Dome Nut
4	1	Rear Leg	17	1	M10 Nylock Nut
5	1	Rubber End Cap	18	1	Multi-Tool
6	1	Internal Seat Rail Bracket	19	1	6mm Allen Key
7	1	Rear Rubber Bumpstop	20	1	8mm Allen key
8	1	Vertical Seat Rail Bolt Dampener	21	2	AA Duracell Battery
9	3	M10 Washer	22	4	Water Treatment Tablet
10	2	M8 Washer	23	1	Siphon
11	1	Plastic Dome cap	24	1	User Guide
12	1	M10x180mm Seat Rail Bolt	Optional Equipment (Not Included)		
13	1	M10x95mm Bolt	25	1	Optional Stand (not included)

» Assembly Instructions

STEP 1

Installing the Seat and Rear Leg to Seat Rail

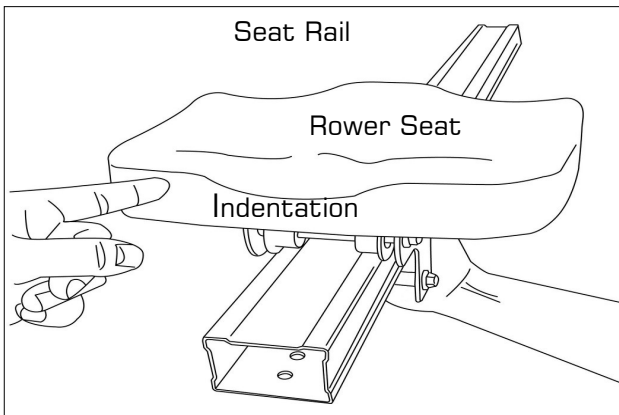

Install the **Rower Seat**[3] onto the **Seat Rail**[2] as shown, with seat indentation facing rearward

STEP 2

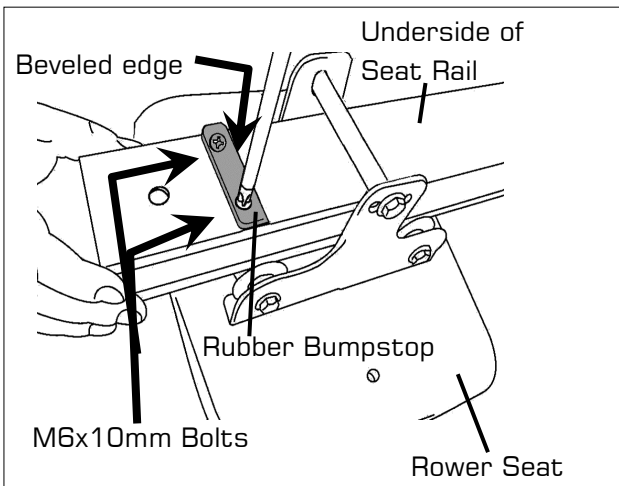

Next, install **Rear Bumpstop** [7] on underside of **Seat Rail** using **2x M6x10mm Bolts**[15]. Beveled edge must face forward.

STEP 3

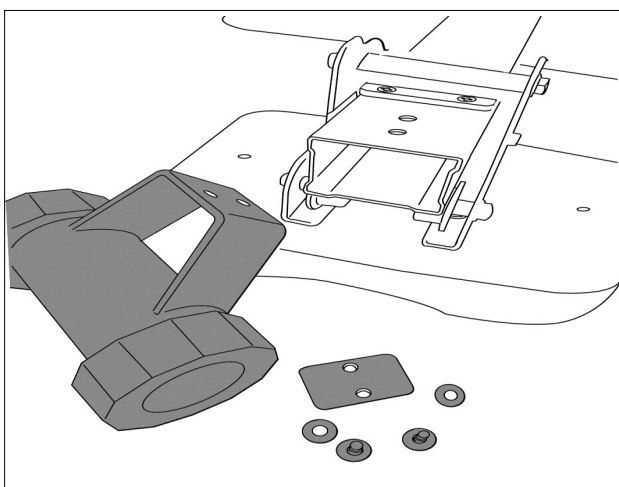

Rear Leg Assembly:

Rear Leg[4]

Internal Seat Rail Bracket[6]

M8x15mm Bolt[14]

M8 Washer[10]

» Assembly Instructions

STEP 4

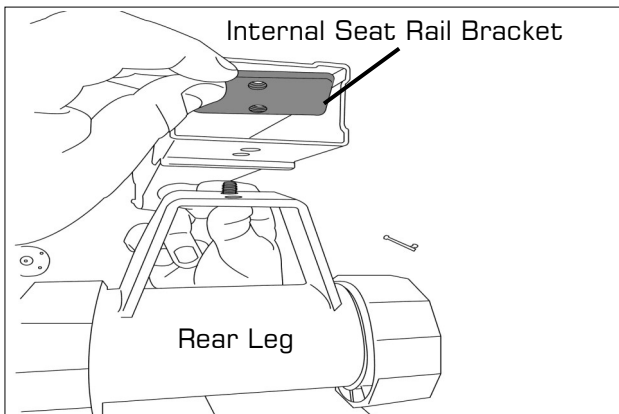

Tip:

Install front **M8x15mm bolt[14]** and **M8 washer[10]** first.

STEP 5

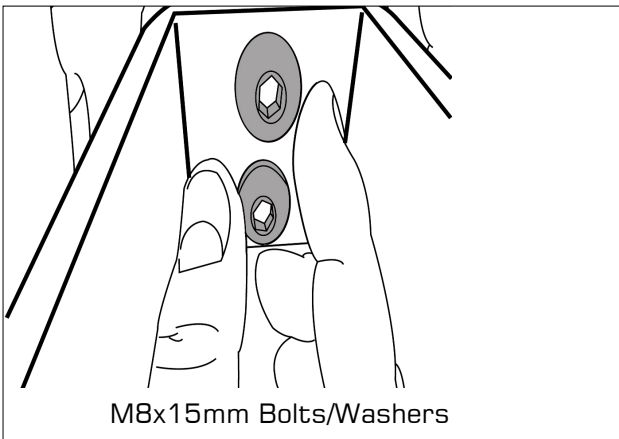

Mount Rear Leg as shown, aligning the **M8x15mm Bolts[14]** and **M8 Washers[10]** up through the Rear Leg, the bottom of the Seat Rail and threading into the Internal Seat Rail Bracket as illustrated.

STEP 6

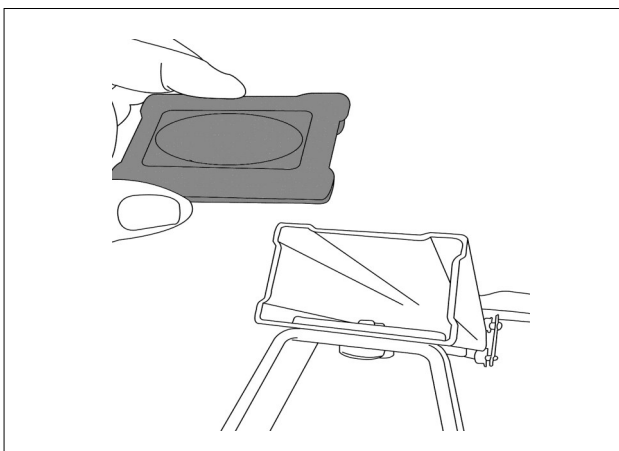

Install **Rubber End Cap[5]** once Rear Leg assembly is completed.

» Assembly Instructions

STEP 7

Installing the Seat Rail to Mainframe

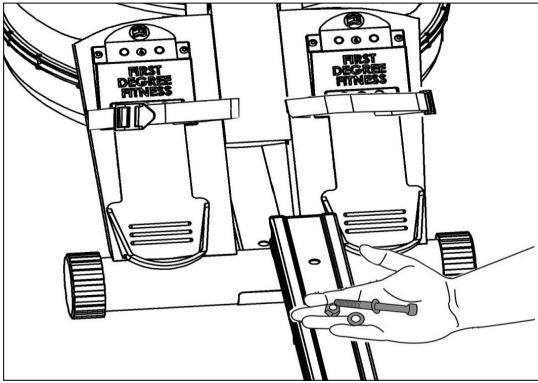

M10x95mm Bolt[13] , 2xM10 Washer[9]
and M10 Dome Nut [16]

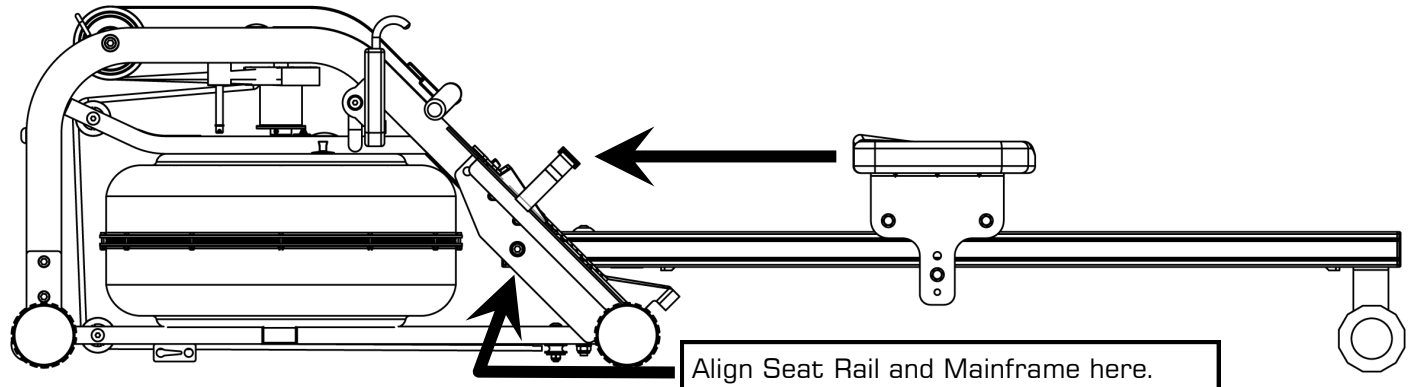

Insert the Seat Rail until it just slightly protrudes behind the Footplate. Shown here is the installation/alignment point for the M10x95mm Horizontal Seat Rail Bolt, M10 Washer and Dome Nut. Install and secure.



M10x95mm Bolt[13] , 2xM10 Washer[9]
and M10 Dome Nut [16]

STEP 8

Installing the Vertical Seat Rail Tensioning Bolt

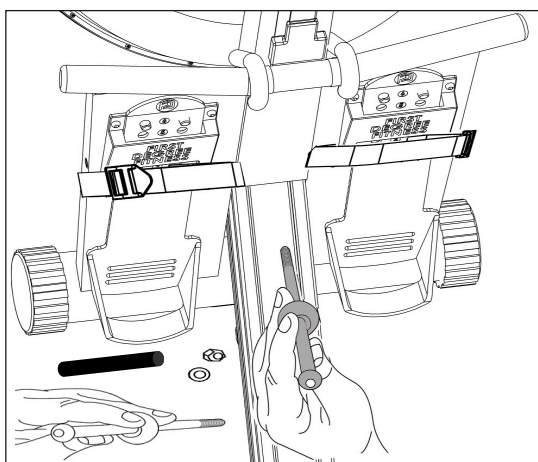

Install the Vertical Seat Rail Tensioning Bolt through the Seat Rail as shown, then fit the Vertical Seat Rail bolt Dampener onto the bolt between the bottom of the Seat Rail and the Lower Frame (**not shown**) before securing bolt with M10 Nylock Nut and Washer

Do not tighten. See following page for correct height adjustment.

M10x180mm Seat Rail Bolt[12], Plastic Dome Cap [11], Vertical Seat Rail Bolt Dampener[8], M10 Nylock Nut[17] and M10 Washer[9].

» Fine Tuning the Fluid Rower

The Vertical Seat Rail Tensioning Bolt is designed to hold the mid leg 3-5mm off the ground when the Fluid Rower is un-weighted, and just slightly touch the ground during a rowing stroke.

Tighten the assembly until the Mid Leg begins to lift off of the ground as shown below.

If excessive head shaking/hopping occurs during rowing, the likely cause is the Vertical Seat Rail Tensioning Bolt being out of adjustment.

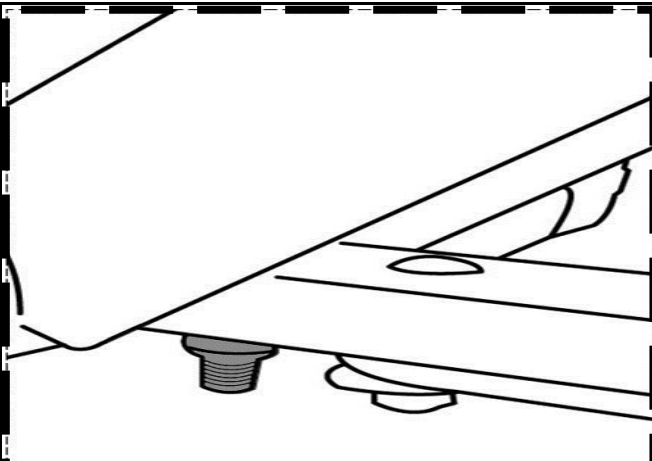
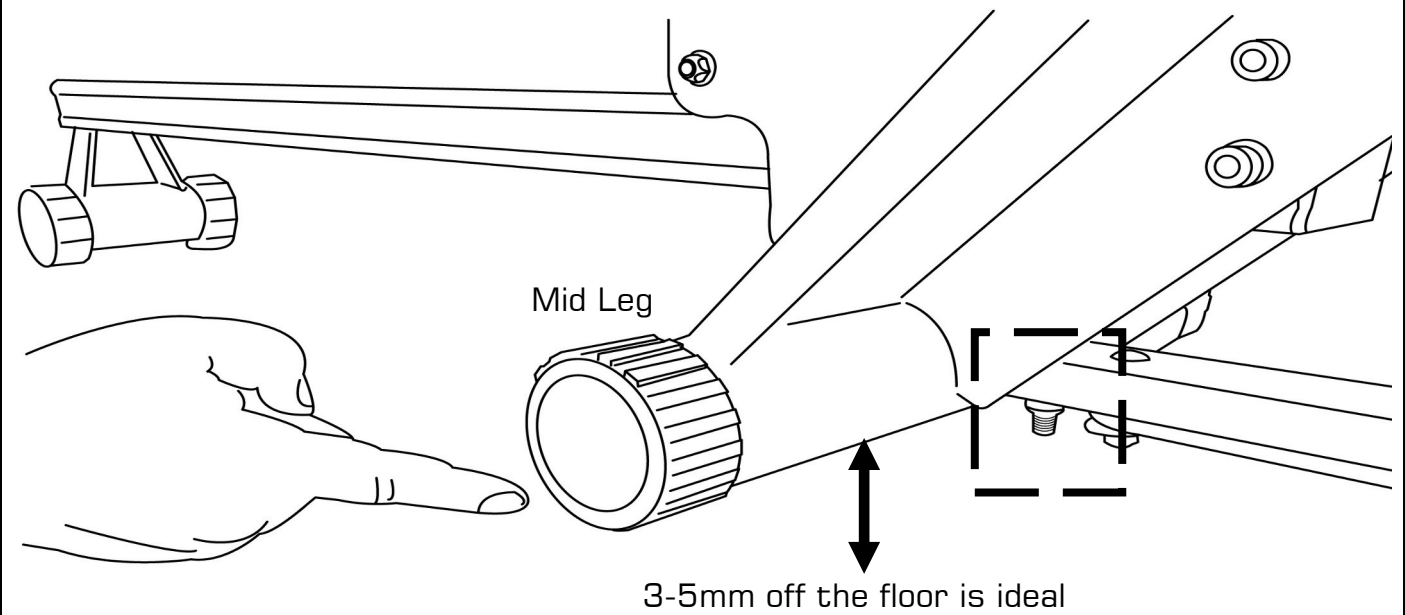

Close up view of the Vertical Seat Rail Tensioning Bolt M10 Nylock location.

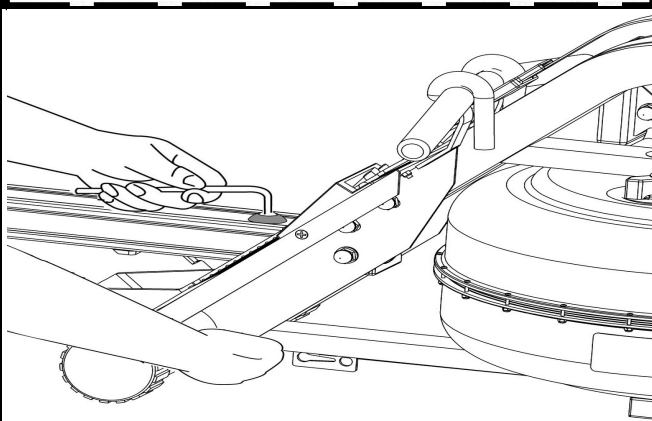

Tension the Vertical Seat Rail Tensioning Bolt as shown here.

» Adjustable Resistance (AR) Tank

The Adjustable Resistance (AR) Tank, developed and patented by FIRST DEGREE FITNESS, offers a true multi-level experience. Water is moved between the "storage" and "active" chambers of the AR Tank. Your new Rowing Ergometer can adapt - at the turn of a dial - to the resistance preferred by each user in the home environment.

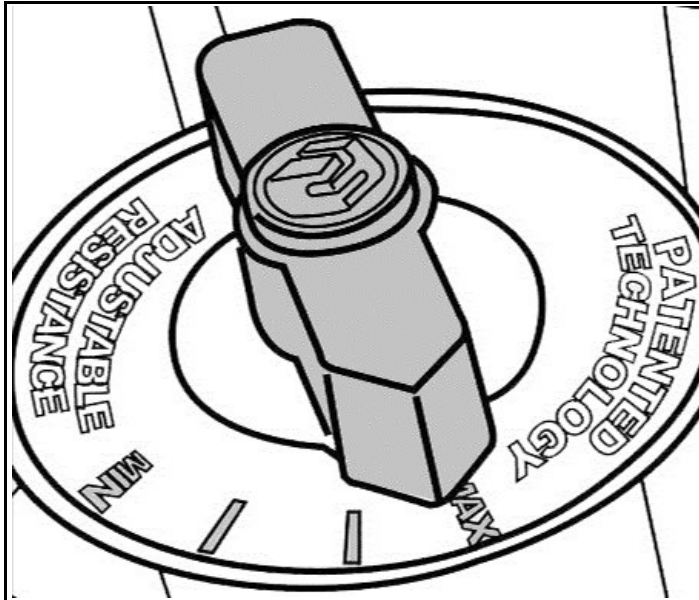

MAX: This setting allows the maximum amount of water to reach the flywheel for heaviest resistance

MIN: Keeps a portion of the water in reserve creating light resistance.

Getting Started

To achieve minimum resistance, select "MIN" on the tank adjuster. **It takes 10 strokes to fill the central (storage) tank, leaving a minimal amount of water in the outer (active) tank. This process is always required if minimum resistance is desired.** Row hard at a steady pace (20 to 25 strokes per minute [SPM]) and put some effort into the stroke, ensuring that good form is maintained. You can make adjustments to the resistance level while you row. Your Rowing Ergometer will adapt almost instantly to increases in resistance but will take up to 10 strokes to reduce the effort required, as the central (storage) tank fills up.

Developing Your Routine

Once you have found a level that gives you the exercise required, changes can be made to SPM and to stroke intensity to further vary your energy input. Interval training is used by most Rowers, where a period of low intensity is combined with short intervals of high intensity. Your FDF Rowing Ergometer allows for changes 'on the fly', to achieve multi-level resistance profiles during a single workout. For more information on exercise routines, please visit our website at www.firstdegreefitness.com

» Note on Filling the AR Tank



Important: Please Read Before Filling Tank:

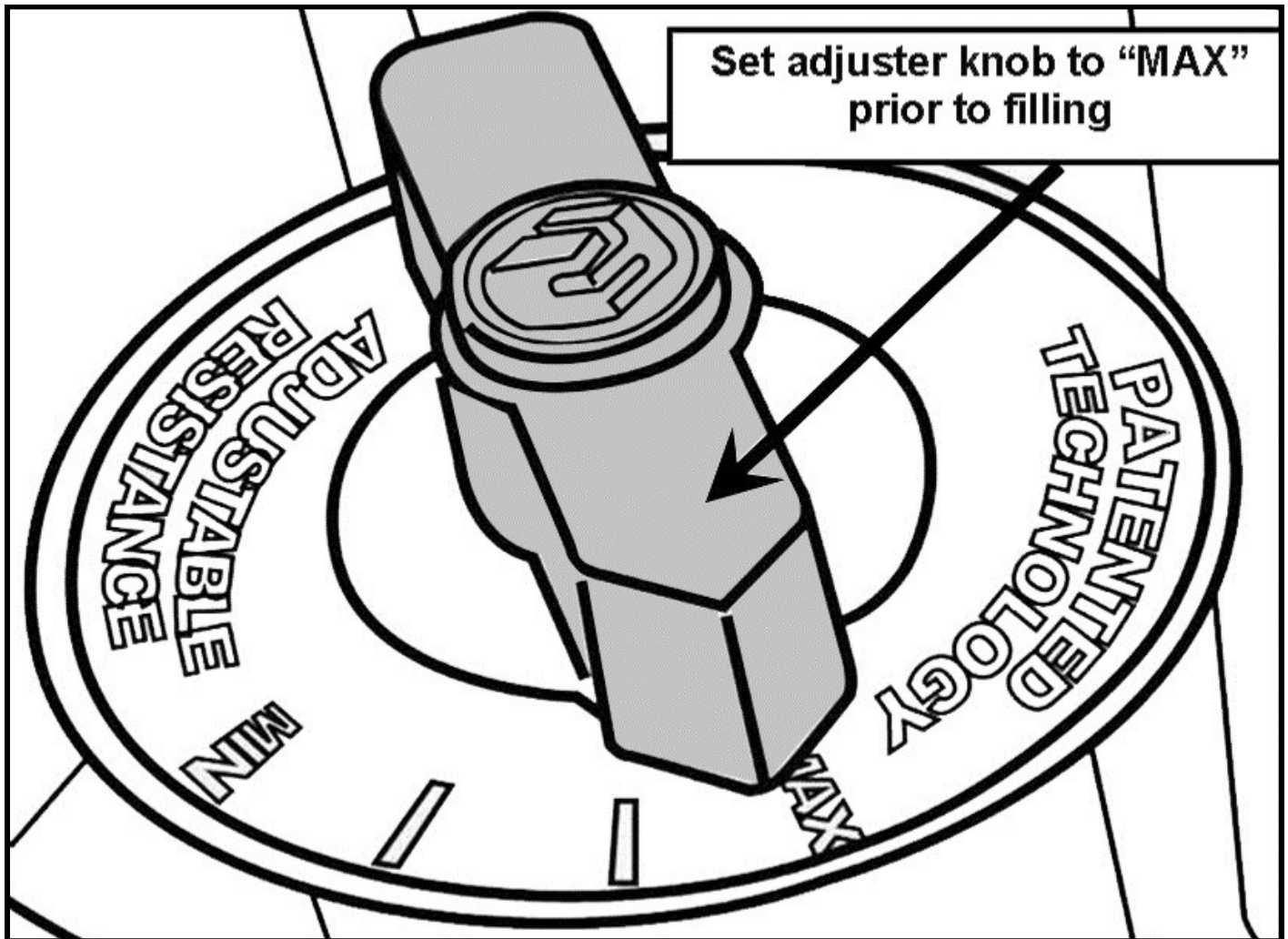

Caution:

When filling the AR tank, the adjuster handle must be set to the “MAX” position as shown to allow accurate fill levels.

Using any other setting other than “MAX” will result in inaccurate fill levels and in extreme cases could cause leakage to occur during use or when stored in the standing position.

DO NOT overfill the tank beyond the maximum indicated level of 17 liters. Refer to the Tank Level Decal on the lower side of the tank

» Tank Filling and Water Treatment

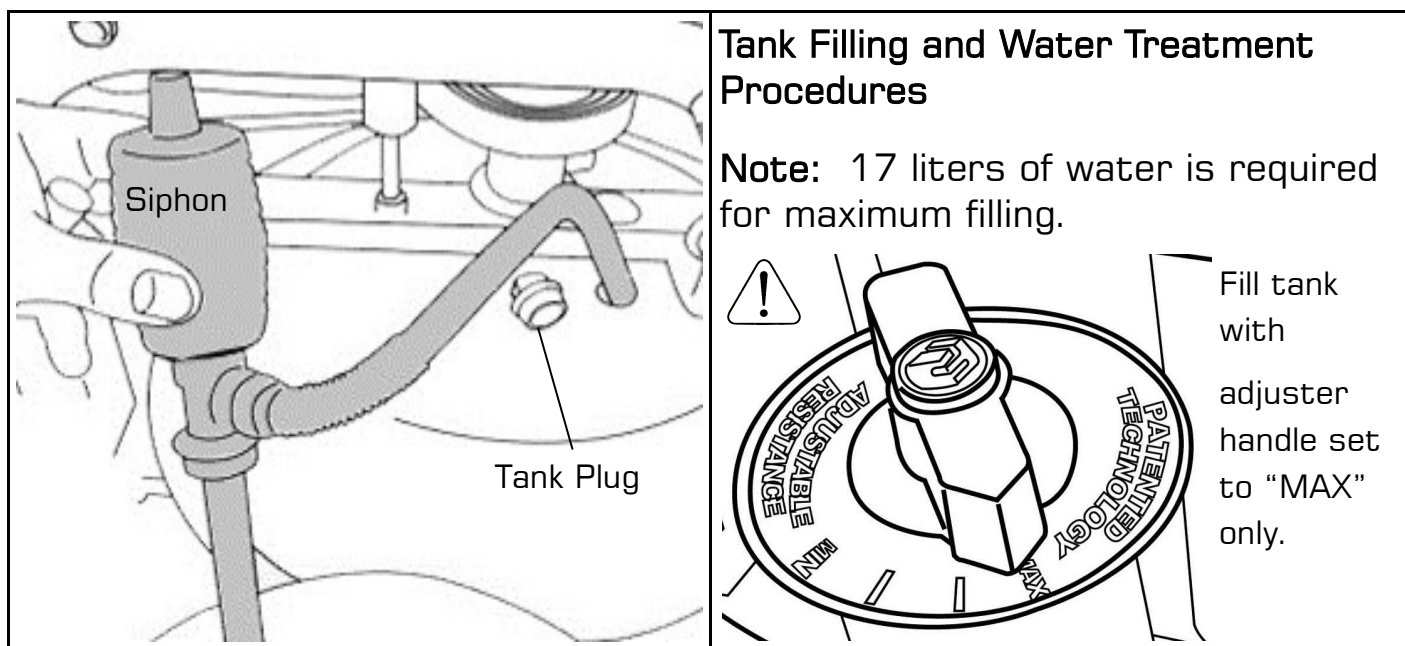

1. Remove Rubber Fill Plug from the top of the tank.
2. Place a large bucket of water next to the rower and position siphon with the rigid hose in the bucket and the flexible hose into the tank as shown. Note: Make sure small breather valve on the top of the siphon is closed before filling.

Note: Where water quality is known to be poor, FDF recommends the use of distilled water.

3. Begin filling tank by squeezing siphon. Use Level Gauge Decal on side of tank to measure volume of water in tank. **Important:** Do not overfill tank!
4. After filling tank to the desired water level, open the valve on the top of the siphon to allow excess water to escape.
5. Ensure that Tank Plug is replaced once filling and water treatment procedures are complete.

Tips on Siphon use: Putting the fill bucket higher than the tank will allow the siphon to "self-pump" when adding water to the tank.

Water Treatment Procedures:

Add One Water Treatment Tablet.

Note: The amount of water treatment can vary widely depending on the Rower's location and exposure to sunlight. DO NOT, UNDER ANY CIRCUMSTANCES USE ANY TREATMENT TABLETS OTHER THAN THOSE SUPPLIED WITH YOUR ROWER. Your rower box contents include 4x Water Treatment Tablets, which is sufficient for several years of water treatment. Treat when water becomes discolored or shows signs of Algae/Bacterial growth. To purchase additional Water Treatment Tablets, please consult your nearest regional dealer/distributor or check our website at www.firstdegreefitness.com



Caution:

Use a drop cloth under the tank when filling the tank to avoid staining floor or carpet.

» Removing/Changing Tank Water

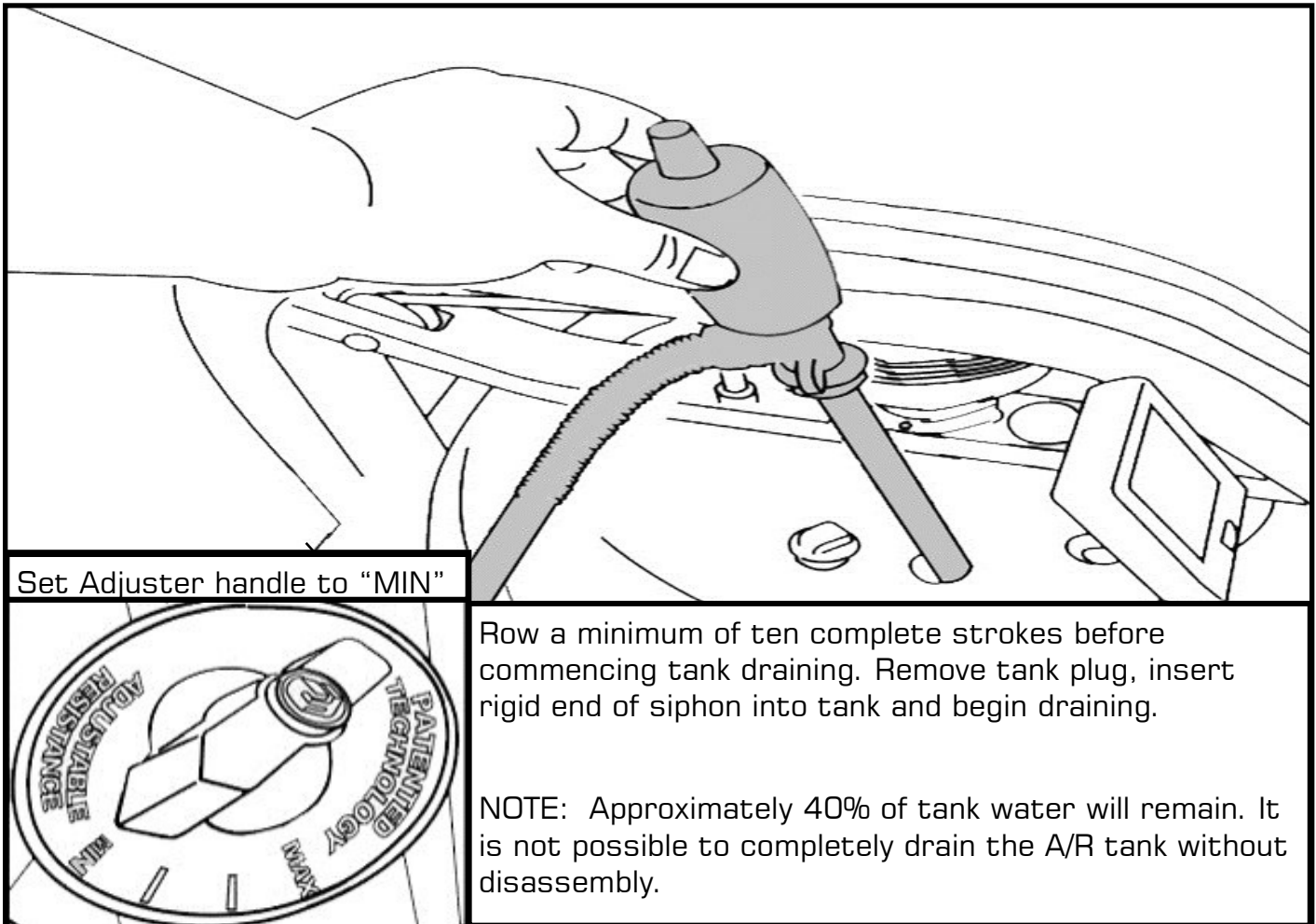

Set Adjuster handle to "MIN"

Row a minimum of ten complete strokes before commencing tank draining. Remove tank plug, insert rigid end of siphon into tank and begin draining.

NOTE: Approximately 40% of tank water will remain. It is not possible to completely drain the A/R tank without disassembly.

1. Set Adjuster handle to "MIN"
2. Row at least ten strokes to fill the storage reservoir as completely as possible.
3. Remove Tank Plug.
4. Insert rigid end of siphon into the tank, and flexible hose into a large bucket.
5. Drain tank (approx. 40% of water will remain) and then refill following directions for Tank filling as described in the Tank Filling section of this manual.

Note: The valve on top of the siphon must be closed to allow proper drainage.

Note: Water treatment will preclude the need to change tank water if the treatment schedule is maintained. Additional Water Treatment Tablet is required only when discoloration appears in the water.

Note: Exposure to full sunlight reduces the life of the Water Treatment Tablets. Storing the rower away from direct sunlight will extend the time between water treatments.

» Slider Footplate

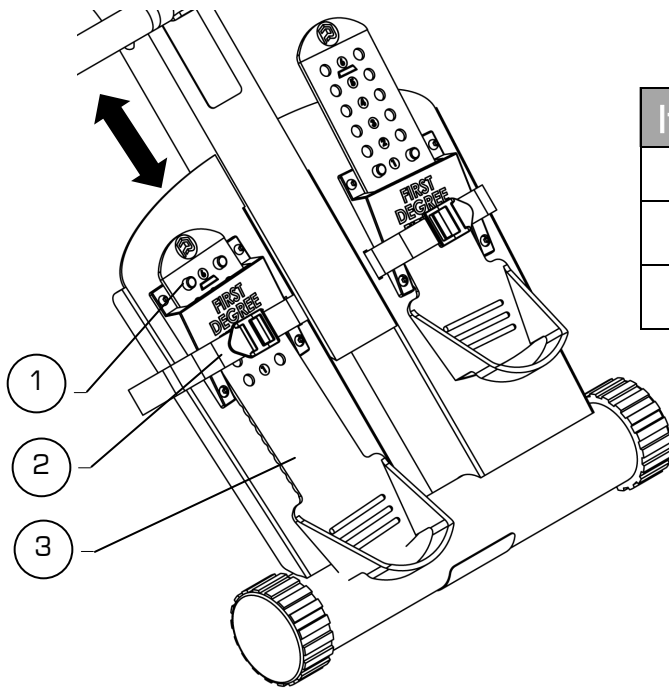

Item	Description
1	Mounting Pegs
2	Footstrap
3	Slide

The Slider Footplate is designed to fit a wide range of foot sizes, and is very simple to use.

To adjust, lift the top of the sliding portion of the footplate and slide up or down. The numbers 1-6 represent a guideline from which the proper length can be determined. Secure the plate onto the mounting pegs and push down firmly to lock into position.





Tighten the Footstraps securely and begin your workout.

WARNING:

Never operate this Rower without feet properly secured in Footstraps, or without the sliding portion of the Slider Footplate locked into position!

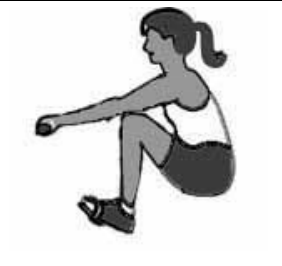
» How to Row?

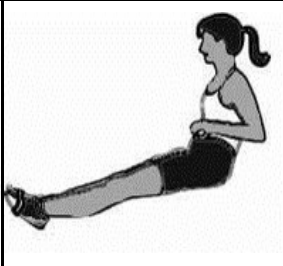
1. Begin the stroke comfortably forward and push strongly back with your legs while keeping your arms and back straight.

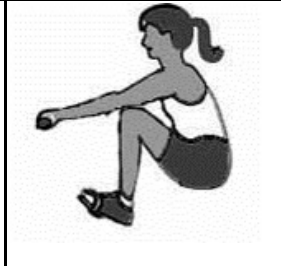
				
<p>Catch Comfortably forward with straight back and arms.</p>	<p>Drive Push with the legs while arms remain straight.</p>	<p>Finish Pull through with arms and legs rocking slightly back on your pelvis.</p>	<p>Recovery Upper body tips forward over your pelvis and move forward.</p>	<p>Catch Catch and begin again.</p>

2. Begin to pull your arms back as they pass over your knees and continue the stroke through to completion rocking slightly back over your pelvis.
3. Return to the starting position and repeat.
4. For further details regarding rowing technique please refer to our international website at www.firstdegreefitness.com

» How Often?

Begin with 5 minute training sessions once a day and aim for around 2:30 to 2:45 for 500m time. Row at a pace that keeps the water circulating continuously between strokes.

Progress a few minutes more each day until you are comfortable with 30-45 minutes training time 3 or 4 times a week.

This will provide aerobic endurance benefits, muscle toning and sufficient calorie burning to form part of a weight loss program.



WARNING

Always consult a doctor before beginning an exercise program.

Stop immediately if you feel faint or dizzy.

» Computer Operation

Functions

Auto Start: Commence rowing to activate.

Reset all values: Press and hold RESET button for 3 seconds.

Distance: Each single press of RESET adds 100m distance, up to 1000m then adds 500m.

Auto-Pause: A temporary halt in exercise will result in the following:

For over 5 seconds and under 5 minutes:

- SPM/500METER/WATT to zero.
- Distance/TIME values are saved.
- CAL per hour defaults to Total CAL.
- A Resumption in exercise in less than 5 minutes will resume Distance/TIME from saved values automatically.

Auto Power Down: Over 5 minutes. All values revert to zero after restart.

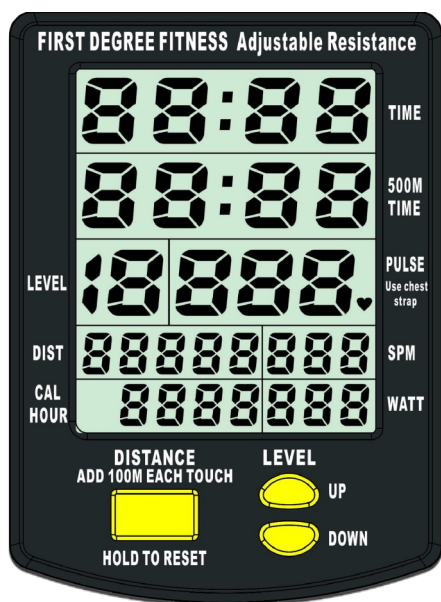

Computer Instructions:

- TIME: Auto start elapsed time.
- 500M TIME: Time to row 500 meters, updated at the completion of each stroke.
- PULSE: Requires optional receiver and chest strap (sold separately).
- SPM: Strokes per minute updated each stroke.
- WATT: Unit of power updated per rowing stroke.



CAL HOUR: Calories burned per hour at the current Watts. Shows total calories burned when exercise is stopped.

***ALL READINGS UPDATED EVERY 2 SECONDS**

NOTE: Heart Rate Kit and Chest Strap is sold separately.

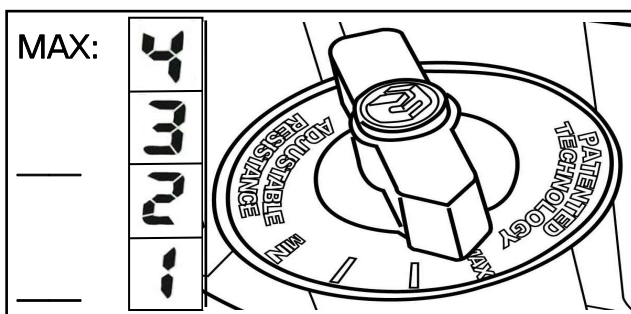

WARNING:

Heart rate monitoring systems may be inaccurate, Over exercising may result in serious injury or death. If you feel faint stop exercising immediately!

» Using the FIRST DEGREE FITNESS USB Interface

Description:

The USB connectivity now built in to all new models of FDF Console and IPM allow you to enhance your exercise experience by connecting to your home PC or Laptop. Using FDF's own sample applications you can exercise while enjoying your favorite movies. NetAthlon 2 XF for Rowers lets you race with other Internet connected rowers in a Virtual Reality 3D environment or train solo.

Setting Up USB connectivity

1. Download and Install the USB Device Driver (CDM2xxxx_Setup.exe for 32 and 64 bit Windows 7/Vista/XP) from the FDF Website.
2. Download and Install the Sample USB Applications from the FDF Website (www.firstdegreefitness.com).
Download and Install NetAthlon 2 XF for Rowers from.
<http://www.webracing.org/downloads.htm>

Connecting Your Console

- The USB Connector is located on a flying lead at the rear of the IPM, along with the Sensor and Heart Rate Monitor Connectors.
- Connect to a Laptop or PC using a standard USB cable, you may need to wait while Windows starts the USB Device Driver.

Note: Please refer to computer manual where applicable or for further information refer to our website at www.firstdegreefitness.com

» Detaching the Rower Belt

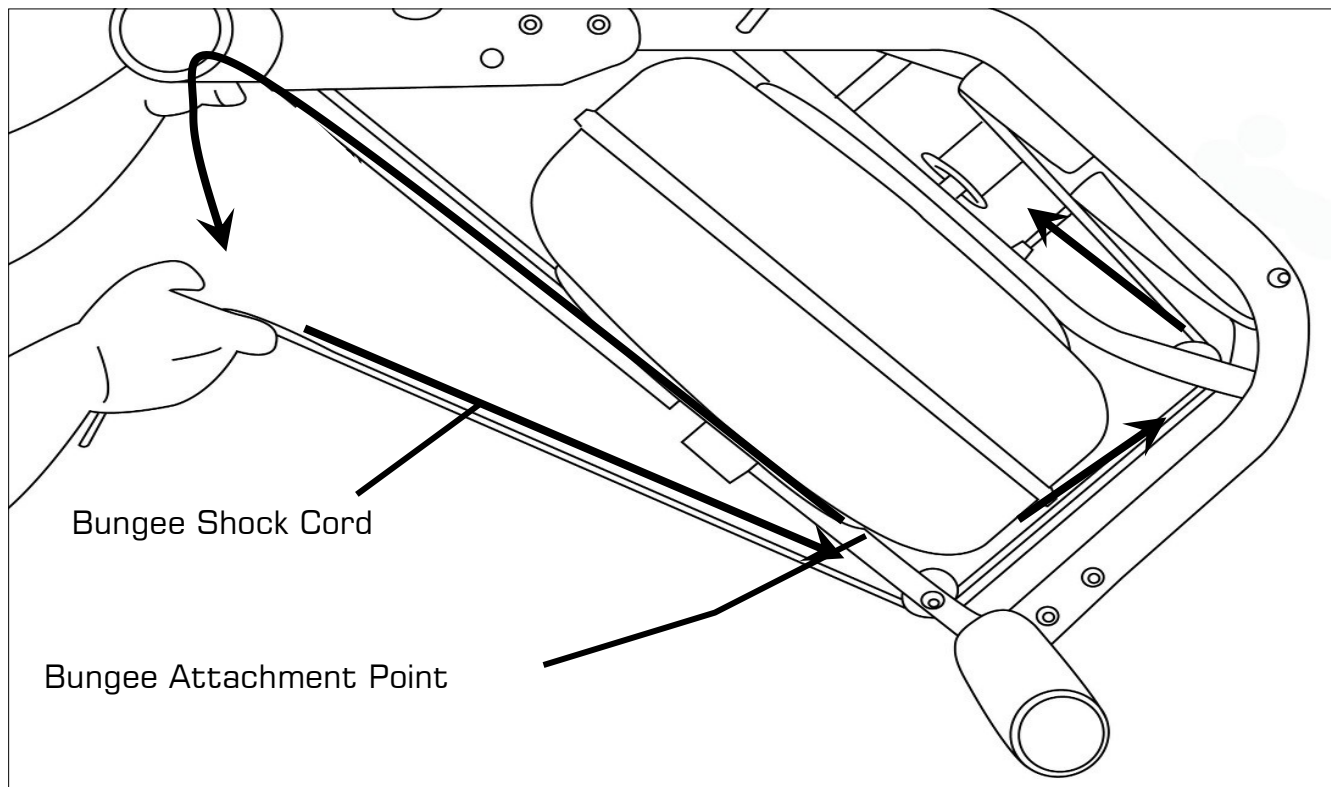

1. To detach belt, simply pull beyond the range of the normal rowing stroke until the belt detaches from the Belt Bungee Pulley.

Tip: You'll hear the Velcro separating just before the belt detaches.

2. Cut plastic tie holding bungee at the Bungee Attachment Point, pull the Cord through all three pulleys and leave excess on top of the tank for now.

» Reattaching the Rower Belt

STEP 1

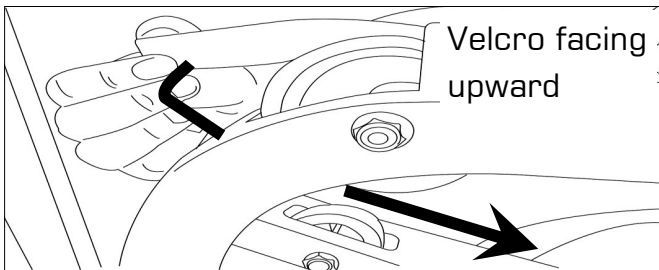

Begin reattaching the Rower Belt by threading around the Rower Belt Pulley with the Velcro side facing upward as illustrated.

STEP 2

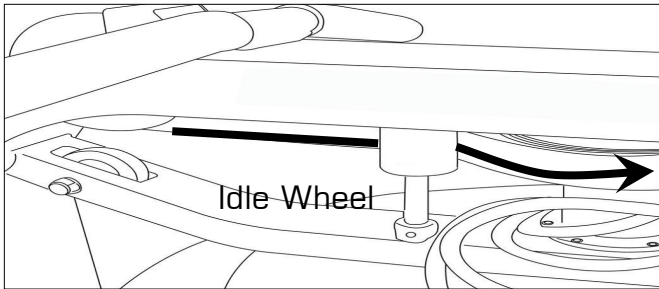

Next, thread the Belt around the Idle Wheel as shown. Once around the Idle Wheel, attach the Rower Belt to the Belt/Bungee Pulley. There is an obvious “lip” at the attachment point.

STEP 3

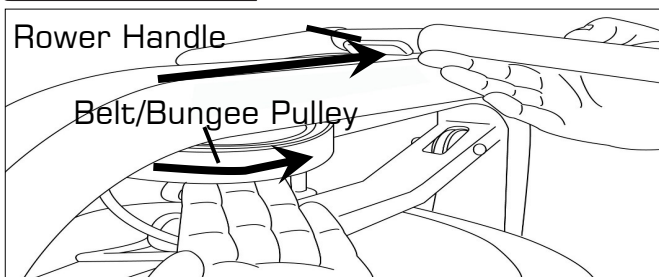

Wind the Rower Belt onto the Belt/Bungee Pulley until the Rower Handle is as it's furthest forward position.

STEP 4

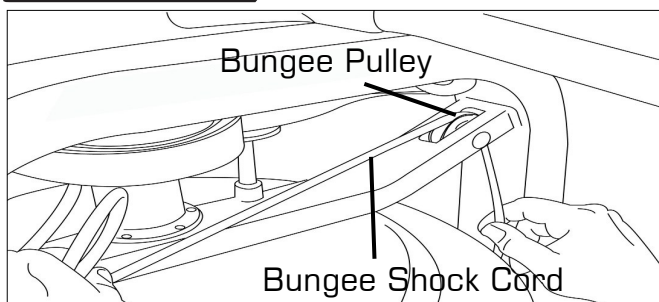

Rethread the Bungee Shock Cord (on opposite side of the Idle Wheel) back through the Bungee Pulleys and tie off at the Attachment Point.

STEP 5

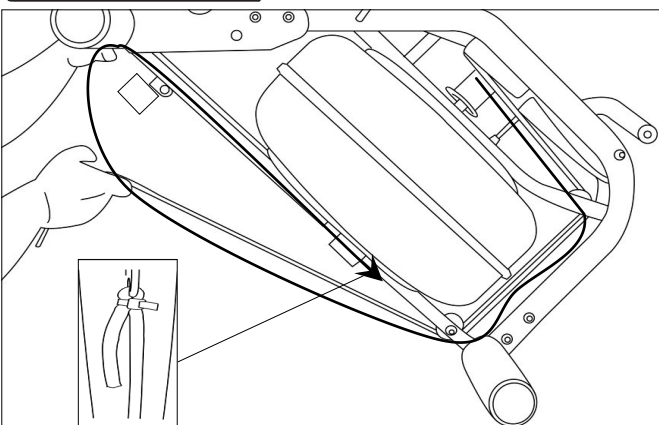

If Bungee Shock Cords previous tension seemed correct (a good way to judge is if the Rower Handle can make it to the furthest point forward on the top of the Mainframe under bungee tension alone) then simply tie off at previous position. If the return is too slack, experiment by tightening the tension in small increments and testing until the correct tension is achieved. If the Rower Handle cannot reach the end of the seat rail during a rowing stroke, then the Bungee Shock Cord is over-tensioned.



Hint

» Removing the Bungee Shock Cord

STEP 1

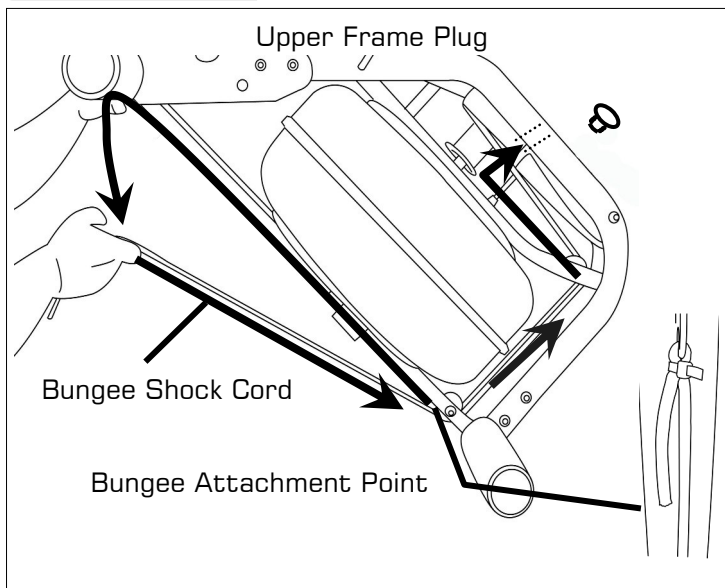

Move the Rowing Handle to its farthest forward point on the Mainframe, then cut the plastic end tie and follow the drawing above for bungee removal. Next, remove the Upper Frame Plug to allow the Bungee Shock Cord to be threaded through the top of the frame. Note: You will need to rotate the Belt/ Bungee Pulley to align the holes properly. Should the belt drop off of during the bungee change, please refer to the previous pages for "Attaching/ Reattaching the Rower Belt".

STEP 2

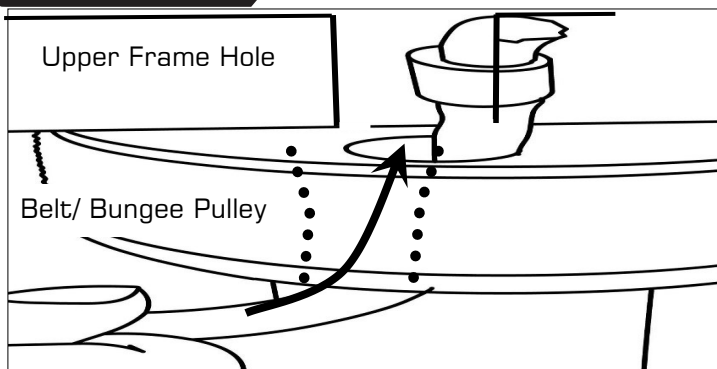

Once Bungee Cord and Upper Frame Hole are aligned, push the Bungee Cord up and through the frame as shown

» Replacing the Bungee Shock Cord

Reinstall the Shock Cord through the Upper Frame, along the opposite side of Idle Wheel, through the Mid Frame and Lower Bungee Pulleys and then tie off with plastic tie wrap to correct tension. Replace Frame Plug.

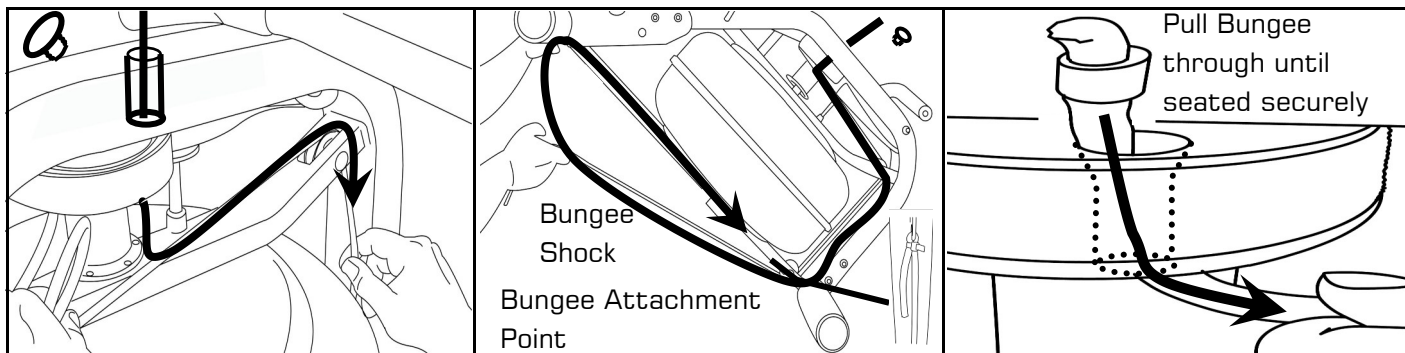

Tip: Correct bungee tension is achieved when enough recoil is present for the Rowing Handle to easily reach the front of the Fluid Rower Pulley Belt Bracket at the far front of the frame. If the Rowing Handle will not reach rearward to the end of the Seat Rail, the Bungee Cord is over-tightened and will require adjustment.

» Maintenance

All preventive maintenance activities must be performed on a regular basis. Performing routine preventive maintenance actions can aid in providing safe, trouble-free operation of all FIRST DEGREE FITNESS equipment.

FIRST DEGREE FITNESS is not responsible for performing regular inspection and maintenance actions for your machines. Instruct all personnel in equipment inspection and maintenance actions and also in accident reporting and recording.

Item	Time Frame	Instructions	Notes
Seat Wheels and Rail	Weekly	Wipe down Seat Wheels and Rail with lint free cloth.	
Frame	Weekly	Wipe down Frame with lint free cloth.	
Tank and Water Treatment	12 months to 2 years	Follow instructions as specified in the "Water Treatment" section of this manual.	
Bungee Cord	Check every hundred hours for correct tension and for signs of wear.	The Bungee Cord should last for many years. If a Bungee Cord change is required, please contact your local service representative or go online at www.firstdegreefitness.com for further details.	
Rowing Belt	Check every hundred hours for correct tension and for signs of wear.	The Rowing Belt should provide many years of trouble free use. If a rowing belt change is required, please contact your local service representative or go online at www.firstdegreefitness.com for further details.	

» Troubleshooting

Fault	Probable Cause	Solution
Water changes color or becomes cloudy.	Fluid Rower is in direct sunlight or has not had water treatment.	Change Rower location to reduce direct exposure to sunlight. Add water treatment or change tank water as directed in the water treatment section of this manual. Consider using distilled water to refill tank.
Rower Belt slipping off belt/ bungee pulley.	Bungee not under enough tension.	Tighten bungee cord following the instructions in "Replacing the Bungee/Shock Cord" section of this manual.
Front of the Rower lifts slightly during vigorous rowing.	M10X150mm Vertical Seat Rail Tensioning Bolt is slightly too loose.	Tighten bolt 1/2 turn and row again. Tighten as needed until problem stops. Note: Over tightening this bolt can damage the seat rail. Only tighten bolt in small increments until fault is corrected.
The Rower Computer does not illuminate after battery installation.	Batteries installed incorrectly or need replacing.	Reinstall batteries in correct position and try again. If the LCD screen fails to illuminate, try rotating the batteries slightly in the computer. If this fails, contact your local service center.
The Rower Computer screen illuminates, but does not register when rowing.	Loose or failed connection.	Check that the computer lead is connected properly. If it is connected then contact your local service center.

» Optional Fixture Kit Installation

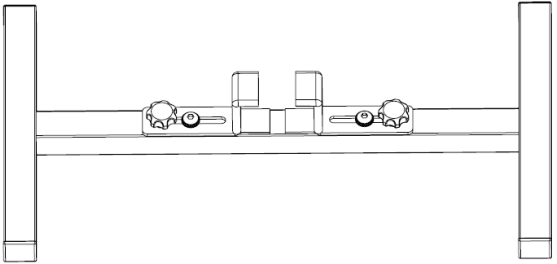
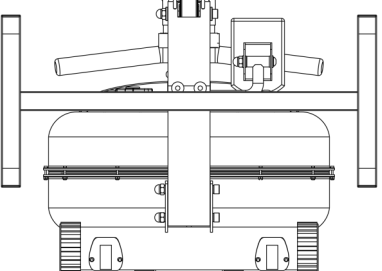
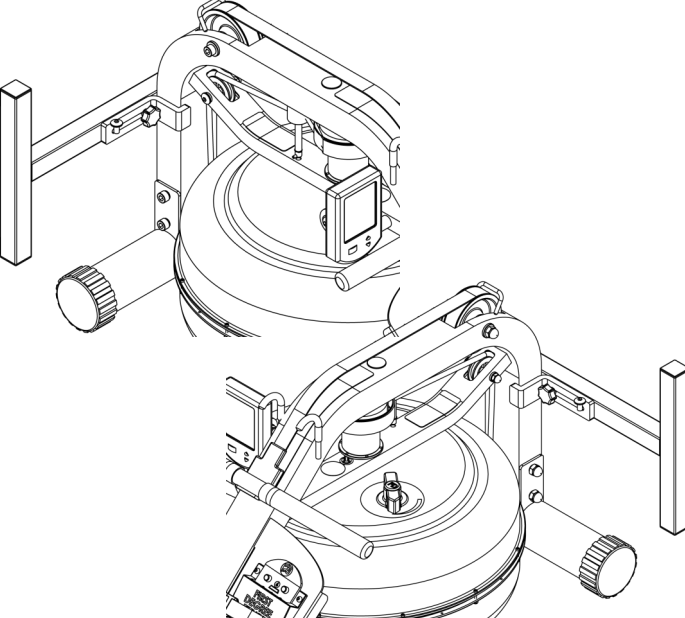
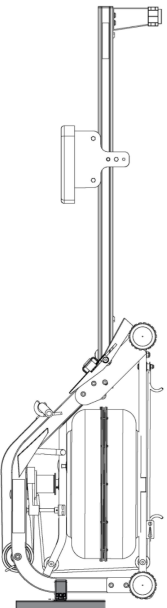
	<p>1. Install the Z bracket onto the Storage Base.</p> <p>Note: Do not tighten the Knob and the Bolt.</p>
	<p>2. Install the bracket onto the rower as shown.</p>
	<p>3. Tighten the Z Bracket knob to fix to the rower.</p> <p>Note: Ensure the Z bracket is secure before tightening.</p>
	<p>4. Stand the rower up vertically.</p> <p>5. Use the 8mm Allen wrench (Included in the product hardware kit) to tighten the Bolts.</p>

» Product Exploded Diagram

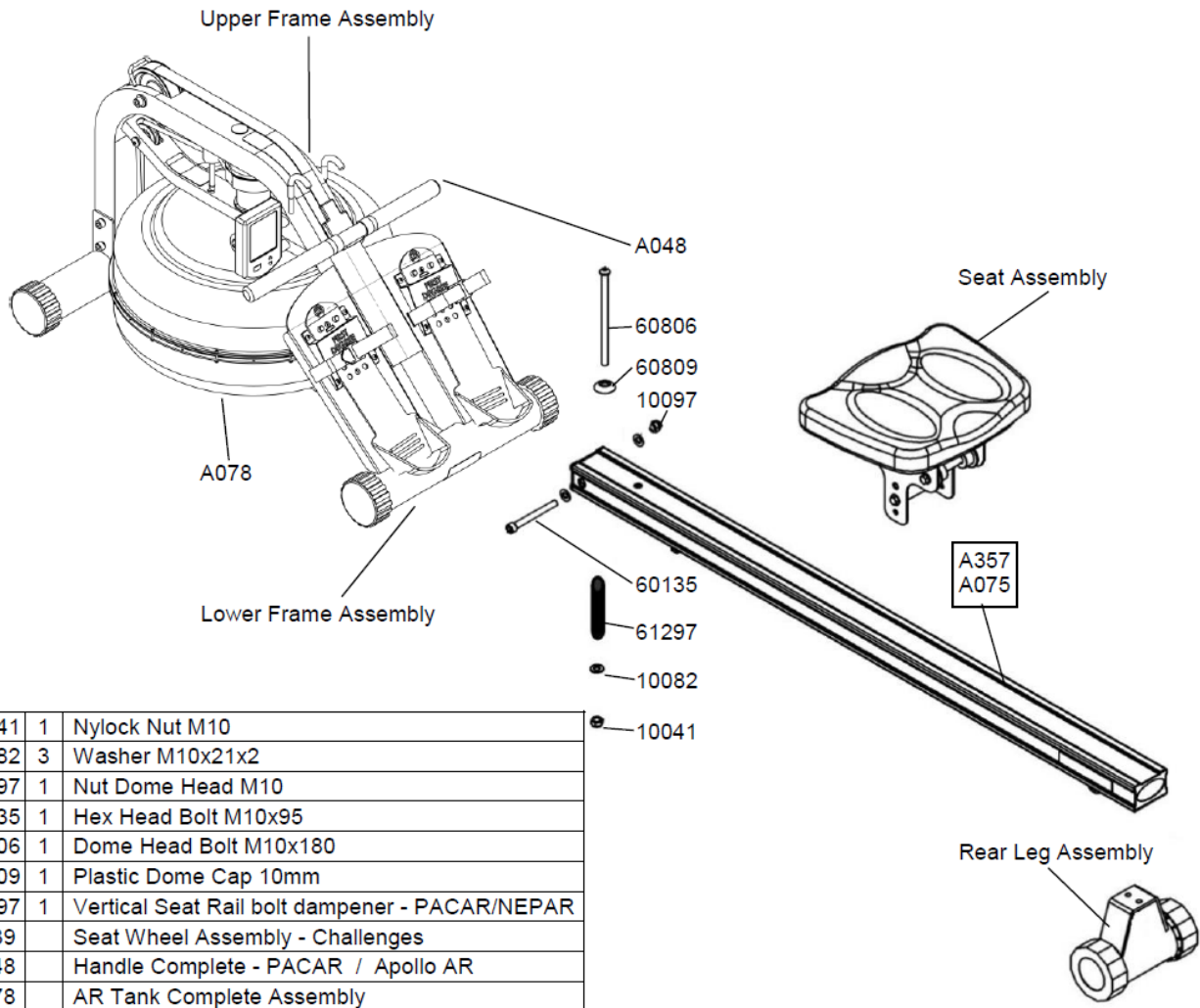

10041	1	Nylock Nut M10
10082	3	Washer M10x21x2
10097	1	Nut Dome Head M10
60135	1	Hex Head Bolt M10x95
60806	1	Dome Head Bolt M10x180
60809	1	Plastic Dome Cap 10mm
61297	1	Vertical Seat Rail bolt dampener - PACAR/NEPAR
A039		Seat Wheel Assembly - Challenges
A048		Handle Complete - PACAR / Apollo AR
A078		AR Tank Complete Assembly

Upper Main Frame Assembly

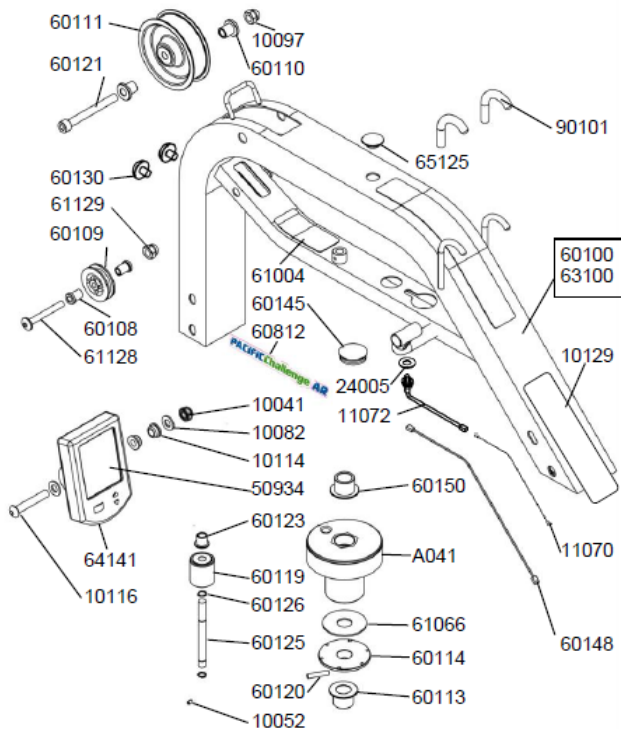

10041	1	Nylock Nut M10
10052	1	Socket Set Screws M4x6 - B
10082	2	Washer M10x21x2
10097	1	Nut Dome Head M10
10114	2	Computer Mount Plastic Bushing
10116	1	Dome Head Bolt M10x60
10129	1	Decal - "How to Row "
11070	1	Sensor Connecting Cable 300mm
11072	1	Sensor 100mm
24005	1	Washer M11x22x1t SUS
50934	1	LCD for L4/L16
60100	1	Upper Main Frame - Pacific
60108	2	Bungee Pulley Spacer 8mm
60109	1	Bungee Pulley 50mm
60110	2	Belt Pulley Spacer 10x24x23
60111	1	Belt Pulley 100mm & 2x Bearing #60112
60113	1	Main Shaft Oil Bushing - Lower 38x20x22
60114	1	Magnet Ring & 6 x Magnet #60124
60119	1	Idle wheel & 2x Bearing #60112
60120	1	Roll Pin M6x30
60121	1	Hex Head Bolt M10x90
60123	1	Idle Shaft Upper Frame Mount 10mm
60125	1	Idler Pulley Shaft
60126	2	C Clip 10mm
60130	2	Frame Rubber Bumper
60145	1	Frame Plug 38.1mm
60148	1	Heart Rate Lead- 400mm
60150	1	Main Shaft Nylon Bushing - Upper
60812	1	Decal - PACIFIC CHALLENGE AR
61004	1	Main Frame Upper Warning Decal - Orange
61066	1	Plastic Washer M5920.1x2T
61128	1	Dome Head Bolt M8x65
61129	1	Nut Dome Head M8
63100	1	Upper Main Frame - NPTAR
64141	1	Computer with USB - L4
65125	1	Rubber End Cap - Main Frame
90101	2	Rubber Hook Cover
A041	1	Belt Bungee Pulley Complete Kit

» Product Exploded Diagram

Lower Main Frame

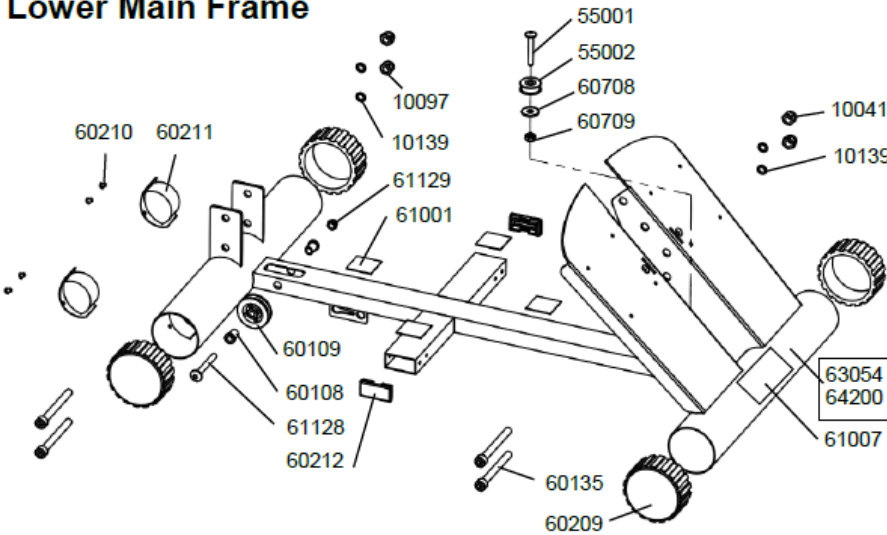

10041	2	Nylock Nut M10
10097	2	Nut Dome Head M10
10139	4	Spring Washer M10
55001	1	Dome Head Bolt M8x50
55002	1	Small pulley 8mmx31.5mm
60108	2	Bungee Pulley Spacer 8mm
60109	1	Bungee Pulley 50mm
60135	4	Hex Head Bolt M10x95
60209	4	End Cap 76.2mm Round
60210	4	Transport Wheel Fastener
60211	2	Transport Wheel 76.2
60212	2	End Cap 25x50mm
60708	1	Washer M8x19x1.6
60709	1	Nylock Nut M8
61001	4	Tank Bonding Strip 3M-VHB
61007	1	Decal - Lower Main Frame Warning
61128	1	Dome Head Bolt M8x65
61129	1	Nut Dome Head M8
63054	1	Lower Frame - PACAR
64200	1	Lower Frame - NPTAR

Sliding Footplate Assembly

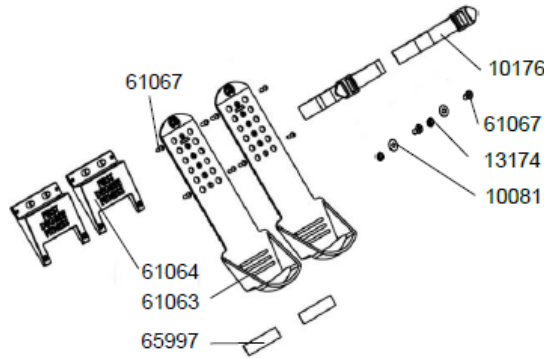

10081	2	Washer M6x16x1
10176	2	Foot Strap & Buckle
13174	2	Nylock Nut M5
61063	2	Footplate Slider with Velcro #65997
61064	2	Footplate Slider Base 120x111x22.8
61067	10	Dome Head Bolt M5x15
65997	2	Velcro For Sliding Footplate

A078—AR Tank Complete Assembly

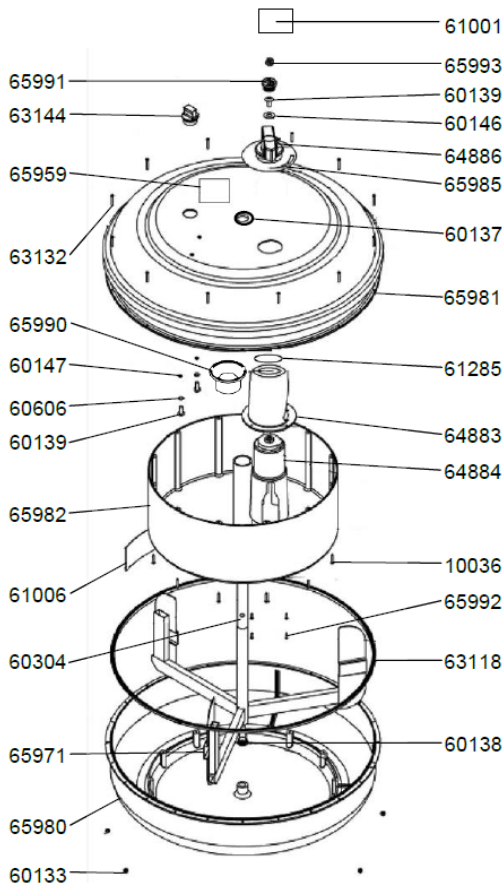

10036	12	Counter Sink Tapping Screw M3x20-SUS
60133	12	Nylock Nut M3-SUS
60137	2	Tank / Main Frame Impeller Shaft Spacer 19.9x40x1
60138	1	Impeller End Cap
60139	3	Dome Head Bolt M6x15-SUS
60146	1	Washer M6x16x1-SUS
60147	2	O- Ring 9.5x6.5x1.5
60304	1	Flywheel Upper Shaft
60606	2	Plastic Washer M6x15x2.5-B
61001	1	Tank Bonding Strip 3M 40x40mm
61006	1	Decal - HS Tank Level
61285	1	Rubber Spacer
63118	1	Tank Large Ring Seal -YELLOW 499x5.8
63132	12	Allen Key Bolt M3x20-SUS
63144	1	Tank Plug For HS Tank
64883	1	Tank Adjuster Outer Cup - 107C
64884	1	Tank Adjuster Inner Cup - 107C
64886	1	Adjuster Knob - 107C
65959	1	Decal - How to Adjust Resistance
65971	1	Impeller - AR
65980	1	Lower Tank Shell
65981	1	Upper Tank Shell & Decals & Spacer #60137 - Outer
65982	1	Inner Reserve Tank Shell
65985	1	Decal - AR Resistance
65990	1	Rubber Caldera
65991	1	End Cap - Adjust Knob
65992	4	Counter Sink Bolt M3x12-SUS
65993	1	Decal- FD Knob 18mm

» Product Exploded Diagram

Seat Assembly

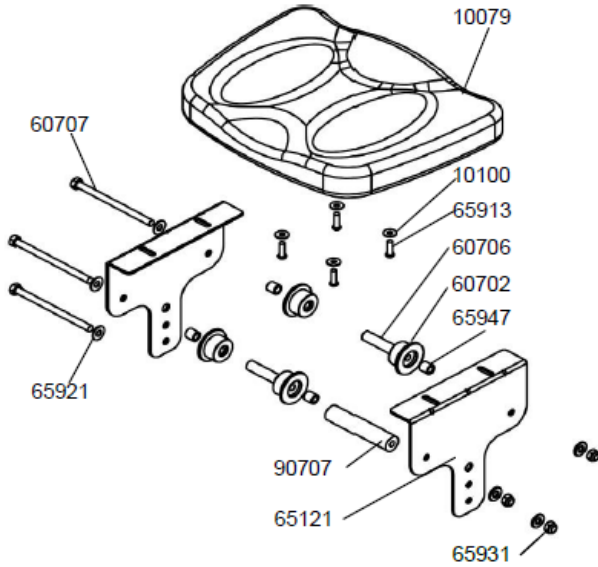

10079	1	Seat LS-E28
10100	4	Washer M6x16x1 -B
60702	4	Seat Wheel - HS
60706	2	Inner Axle Bushing Long
60707	3	Hex Bolt M8x120mm
65121	2	Seat Frame Bracket
65913	4	Dome Head Bolt M6x20 -B
65921	6	Washer M8.5x19x1.6t - B
65931	3	Nylock Nut M8 -B
65947	4	Seat Wheel Short Spacer 12.7x8.1x13 - B
90707	1	Lower Seat Wheel Axle Spacer

A039 Seat Wheel Assembly

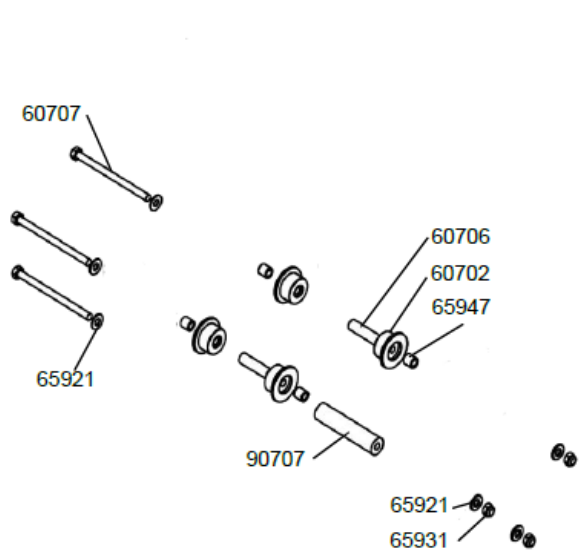

60702	4	Seat Wheel - HS
60706	2	Inner Axle Bushing Long
60707	3	Hex Bolt M8x120mm
65921	6	Washer M8.5x19x1.6t - B
65931	3	Nylock Nut M8 -B
65947	4	Seat Wheel Short Spacer 12.7x8.1x13 - B
90707	1	Lower Seat Wheel Axle Spacer

Rail Assembly & Rear Leg Assembly

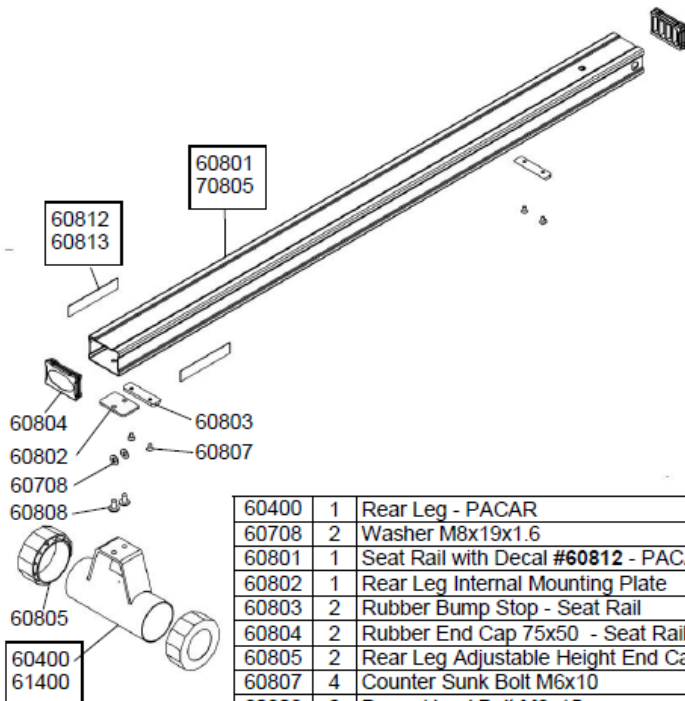

60400	1	Rear Leg - PACAR
60708	2	Washer M8x19x1.6
60801	1	Seat Rail with Decal #60812 - PACAR
60802	1	Rear Leg Internal Mounting Plate
60803	2	Rubber Bump Stop - Seat Rail
60804	2	Rubber End Cap 75x50 - Seat Rail
60805	2	Rear Leg Adjustable Height End Caps
60807	4	Counter Sunk Bolt M6x10
60808	2	Dome Head Bolt M8x15
61400	1	Rear Leg - NPTAR
70805	1	Seat Rail With Decal #60813 - NPTAR

A048 Handle Complete

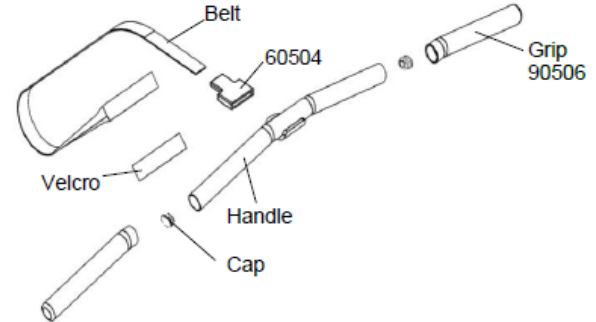

60504	1	Handle/Belt Rubber Cover
90506	2	Handle Grip

A041 Belt Bungee Pulley Complete

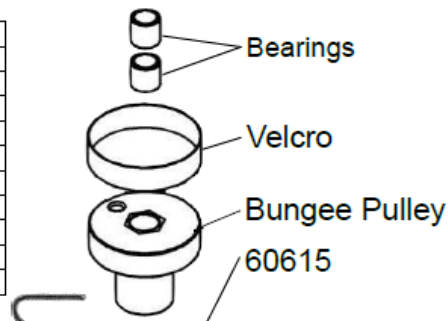

60900	1	Belt Bungee Pulley Complete & Velcro & One Way Bearings #90136
60615	1	Bungee Cord 8mm x 1950 & Crimped End #65922

PACIFIC / NEWPORT / DAYTONA CHALLENGE AR FLUID ROWER

INTERNATIONAL WARRANTY – HOME USE

FIRST DEGREE FITNESS Limited warrants that the **PACIFIC AR / NEWPORT AR / DAYTONA AR Fluid Rower (MODEL PACAR / NPTAR / DAYTONA AR)**, purchased from an authorized agent and in its undamaged original packaging, is free from defects in materials and workmanship. FIRST DEGREE FITNESS Limited or its agent will, at their discretion, repair or replace parts that become defective within the warranty period, subject to the specific inclusions and exclusions below.

Metal Frame – 5 Year Limited Warranty

FIRST DEGREE FITNESS will repair or replace the metal Main Frame of the Fluid Rower should it fail due to any defect in materials or workmanship within 5 years of the original purchase. Warranty does not apply to frame coating.

Polycarbonate Tank & Seals – 3 Year Limited Warranty

FIRST DEGREE FITNESS will repair or replace the polycarbonate tank or seals should they fail due to any defect in materials or workmanship within 3 years of the original purchase.

Mechanical Components (of a non-wearing nature) – 2 Year Limited Warranty

FIRST DEGREE FITNESS will repair or replace any mechanical component should it fail due to any defect in materials or workmanship within 2 years of the original purchase.

Specific Inclusions

Aluminum Seat Rail
Stainless Steel Impeller Assembly

All Other Components (of a wearing nature) – 1 Year Limited Warranty

FIRST DEGREE FITNESS will repair or replace any component should it fail due to any defect in materials or workmanship within 1 year of the original purchase.

Specific Inclusions

Bungee recoil cord, belt and pulley
Hand grips & foot straps
Polyester rowing belt
Seat
All pulleys, rollers & bearings
All rubber components
Computer & speed sensor (excluding replaceable batteries)
Footplates (pivoting & sliding)

General Exclusions

Damage to the finish of any part of the machine
Damage due to neglect, abuse, incorrect assembly or use of the machine
Any charges for freight or customs clearance associated with the return or dispatch of parts
Any damage to or loss of goods during transport of any kind
Any labour cost associated with a warranty claim

General Conditions

- The serial number of the machine must be correctly registered with FIRST DEGREE FITNESS Limited or one of its appointed distributors
- FIRST DEGREE FITNESS Limited reserve the right to examine any part where replacement is claimed under warranty
- Warranty period applies only to the original purchaser from the date of purchase and is not transferable
- The product must be returned to your place of purchase in original packaging with transportation, insurance and associated charges paid for by you and risk of loss or damage assumed by you
- FIRST DEGREE FITNESS makes no other warranties except as stated here and expressly disclaims all warranties not stated in this warranty. Neither FIRST DEGREE FITNESS nor its associates shall be responsible for incidental or consequential damages
- Manufacturer's warranty automatically commences upon sale of the product to end user or upon the expiration of one (1) year from month of manufacture, whichever occurs first



FIRST DEGREE FITNESS
Fluid INNOVATION

FITNESS PRODUCTS INSPIRED BY REAL LIFE

WWW.FIRSTDEGREEFITNESS.COM

CONTACT US

For customer support please visit
firstdegreefitness.com/support

TAIWAN

T: +886 3 478 3306
764 Chung Shan South Rd
Yangmei Taoyuan
Taiwan R.O.C.